

# BENDING RADII FOR COLD FORMING OF SAFETY STEELS

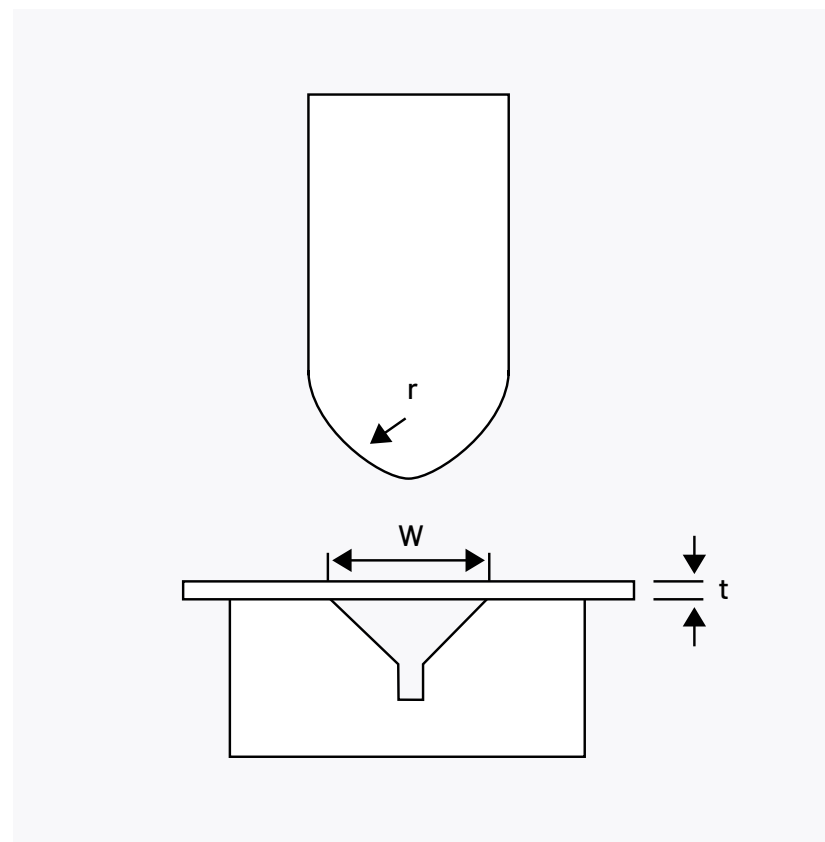

## Recommendations for minimum bending radii

Quality [mm]	Thickness [mm]	r/t 	r/t ⊥
SECURE 400	$t \leq 8$	7	5
SECURE 450	$t \leq 8$	5	4
SECURE 500	$t \leq 8$	8	6

|| = bending axis parallel to rolling direction

⊥ = bending axis perpendicular to rolling direction